

Ductile Iron Butterfly Valve Trigger Lever

Weights: 3kg – 27kg
Sizes: DN 50 – 300
Class: 150
Pressure: PN16
Temperatures: -10°C to 120°C

Application

The VT-N Butterfly Valve Ductile Iron Trigger Lever is a reliable and versatile component in fluid control systems. Constructed from high-quality ductile iron, this valve exhibits exceptional strength, durability, and resistance to corrosion, making it suitable for a wide range of applications. This specific design includes a trigger lever, which enhances its ease of manual operation and allows for precise control and throttling of the fluid flow.

The trigger lever provides a quick activation due to the lever rotation, which accommodates for quick and effortless actuation for valves up to 12" in diameter (DN 300). Locking of the disc is achieved by the trigger levers spring-operated handle-locking plate and pins. Its ergonomic design ensures comfortable handling, reducing operator fatigue during prolonged usage. The lever's positioning also facilitates clear visibility of the valve's open and closed positions, enabling efficient monitoring of the flow status.

Dimensions

NPS	DN	A	B	C	φ D	D1	φ D1	L/F1	Kg
2	50	132	66	43	73	267	125	25	2
2.5	65	144	75	46	85	267	145	25	3
3	80	156	91	46	100	267	160	25	3
4	100	171	107	52	131	267	180	25	5
5	125	192	122	56	155	267	210	25	6
6	150	213	134	56	185	267	240	25	7
8	200	246	167	60	234	360	295	32	13
10	250	284	203	68	288	360	355	32	19
12	300	314	238	78	340	500	410	32	27

Diagram

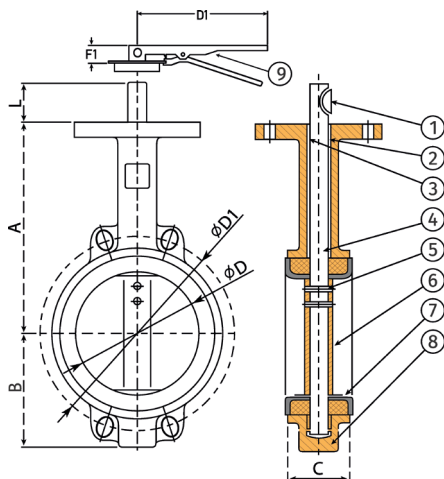

#	Part	Material
1	Key	45# Steel
2	O-Ring	NBR
3	Brushing	PTFE
4	Stem	420 Stainless Steel
5	Pin	316 Stainless Steel
6	Disc	NPDI of CF8M (SS316)
7	Seat (Replaceable)	EPDM (standard), Nitrile, or Teflon
8	Body	Ductile Iron A536
9	Lever	Q235 Steel

Specifications

Models

VT-N

Body Material

Ductile Iron

Iron Grade

ASTM A536 65-45-12

Seat

EPDM (standard), Nitrile, Teflon

Disc

Stainless Steel CF8M, NPDI

Standards

Design conforms to DIN EN593
 End Standard conforms to DIN EN1092
 Face to Face conforms to DIN EN558

Services

Water, Oil, Gas, Steam

Industries

Agricultural Purposes for Compressed Air, Gasses and Oils, Heating and Conditioning (HVAC), Industrial Applications, Water Treatment and Distribution

Priority Media

Animal Fats, Air, Carbon Monoxide, Cement, Ethylene Glycol, Hydrogen Gas, Oxygen Gas, Starch

Inventory Code and Description

TVTSST/LN
 VT-N DI B/FLY WAFER SS T/L
 Ductile Iron Butterfly Wafer Valve Stainless Steel EPDM Disc Trigger Lever

TVTNPDI/LN
 VT-N DI B/FLY WAFER NPDI T/L
 Ductile Iron Butterfly Wafer Valve NPDI EPDM Disc Trigger Lever

TVTSST/LTEFN
 VT-N DI B/FLY WAFER SS T/L TEFLON
 Ductile Iron Butterfly Wafer Valve Stainless Steel Disc Trigger Lever Teflon Seat

Also Known As:

Quarter Turn Valve, Duplex Valve, Lug Valve, Uni-Flow Valve

Butterfly Valves

Models:	VT-N
Class:	150
Sizes:	DN 50 – 300; DN 50 – 700
Pressure:	PN16
Body Material:	Ductile Iron ; CF8M/NPDI Disc
Temperatures:	-10°C to 120°C
Weights:	2kg -27kg ; 5kg - 316kg

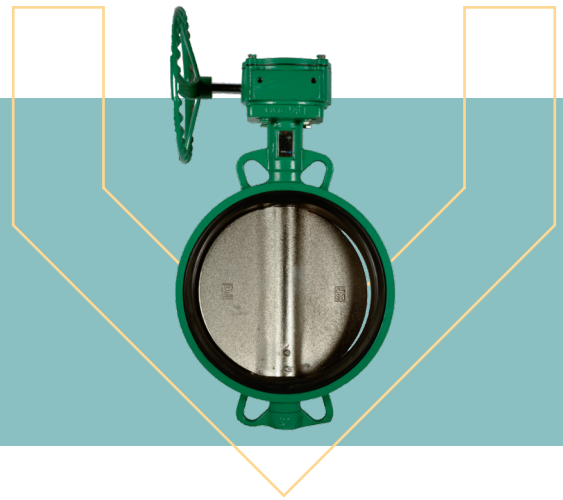

Butterfly Valve Detail

A thinner design makes the Butterfly Valve versatile and well suited for the industrial management of high volumes low-pressure flow of liquids and gasses. Butterfly Valves are excellent for large-flow and pressure applications as well.

Liners are available in EPDM (Standard), Nitrile, and Teflon, and come with two separate Disc options:

- **Stainless Steel CF8M** for use with abrasive and corrosive media such as acids, alkalis, chemicals, and diesel. Must be used with a suitable NBR or Teflon Liner
- **NPDI** for use with idle or non-abrasive or corrosion-resistant media such as water, oil and gas. Can be used with a suitable EPDM Liner

Application

The Wafer Style Butterfly Valve has lugs to secure and align the valve with two mating flanges. From DN50 to DN300, a 90° rotation of the handle opens or closes the valve. For sizes larger than DN300, a gearbox and handwheel enables full and partial opening and closing operations.

The disk is approximately the same size as the adjoining pipe and rotates on a vertical axis. Because the seat is softer, the disc gets pressed firmly against it creating a tight seal when closed.

Torque Figures

DN	NPS	PN6		PN10		PN16	
		Wet	Dry	Wet	Dry	Wet	Dry
DN50	2"	13	20.8	13.9	22.1	15.1	24.2
DN65	2.5"	13.8	26.1	15.4	29.2	17.2	32.7
DN80	3"	21	39.9	21.7	41.1	23.1	43.7
DN100	4"	34.9	63.8	37.1	67.8	39.8	72.8
DN125	5"	53.8	93.8	57.9	101	61.9	108
DN150	6"	84.5	149	93.9	165	102	174
DN200	8"	154	264	173	297	192	330
DN250	10"	249	423	286	486	323	549
DN300	12"	371	605	429	699	490	799
DN350	14"	466	699	550	825	625	969
DN400	16"	632	947	755	1133	846	1307
DN450	18"	831	1246	1012	1518	1131	1787
DN500	20"	1093	1639	1350	2025	1431	2288
DN600	24"	1679	2519	2111	3166	2301	3711
DN700	28"	3008	4515	3269	4908	5670	6380

Butterfly Valve Torque is measured in Newton-Meters and is provided for both Wet and Dry media. It is the Turning Force needed to rotate the valve disc and is dependent on the Gear Ratio (number of turns to open or close the valve).

All measurements listed are expressed in millimetres, unless otherwise noted. Product weight is represented in kilograms. DN size is provided in millimetres and NPS size is given in inches. These values correspond to the diagram label and its associated part.

Specifications

Services

Petrochemicals and Petroleum, Refineries, Primary Energy, Agriculture, Water Works, HVAC

Industries

Water, Oil, Gas, Steam

Priority Media

Acetone, Acetylene, Ammonium Bicarbonate, Dry Cement, Diesel Oil Fuels, Ethane, Dry Flour, Heptane, Nitrogen Gas, Dry Plastics, Dry Sugars, Dry Sulphur Dioxide

Also Known As:

Duplex Valve
Lug Valve
Uni-Flow Valve
Quarter Turn Valve

Advantages:

- **Low maintenance costs** as there are minimal moving parts
- **No spaces** where pockets of gas and media can accumulate
- **Low pressure drop** when fully opened, but can also be used in high flow rate applications
- **Easy installation** and less maintenance as the valve is thin
- **Economical savings** due to its reduced weight and space requirements

Common Industry Uses:

- **Used to start, stop, and regulate flow**
- **Agricultural purposes** used by compressed air, gas, and oil
- **Controlling the flow, pressure, and distribution of water treatment services**
- **Heating and Conditioning (HVAC)** for regulating the flow and cooling of air, water, and gasses
- **Transporting chemicals**, where the Butterfly Valve's compact design and low weight make it ideal for chemical processing